

## ROPE TRACK DRIVE 3000

### TECHNICAL DATA SHEET

September 2018

The RTD 3000 system enables durable motorised track control with a rope mount system and integrated head pulley.

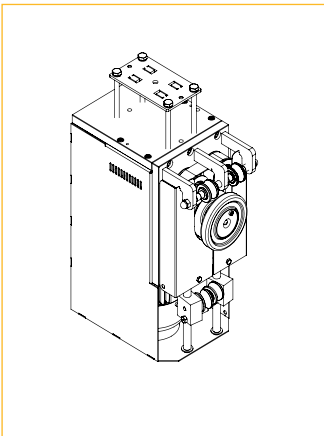

#### » SPECIFICATIONS

- Equipped with an easy to use remote control with open/close switch and speed controller.
- The exclusive toothed belt and pulley creates maximum friction for reliable movement.
- Has step-less speed regulation and a manual emergency override
- Variable speed of 0 to 55 cm/sec.
- Works with H100, ShowPipe and ShowTrack.
- Optional DMX basic module for control through a lighting console.

#### » OUTER DIMENSIONS (MM)

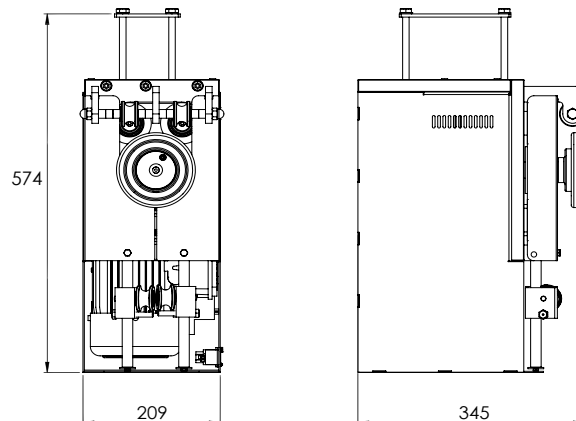

#### » ELECTRONICAL AND MECHANICAL PROPERTIES

- |                               |   |
|-------------------------------|---|
| • Motor torque : 21 Nm        | • Motor Power : 370 W                           |
| • Motor speed : 138 rpm       | • Power in : 1 x 230 V • 1.89 A                 |
| • Maximum rope force : 505 N  | • Power connection : PowerCON 20A - SpeakOn 16A |
| • Rope speed : 0 to 55 cm/sec | • Duty Cycle : S1 - Continuous Duty             |
| a                             | A   |

» COMPONENTS (MM)

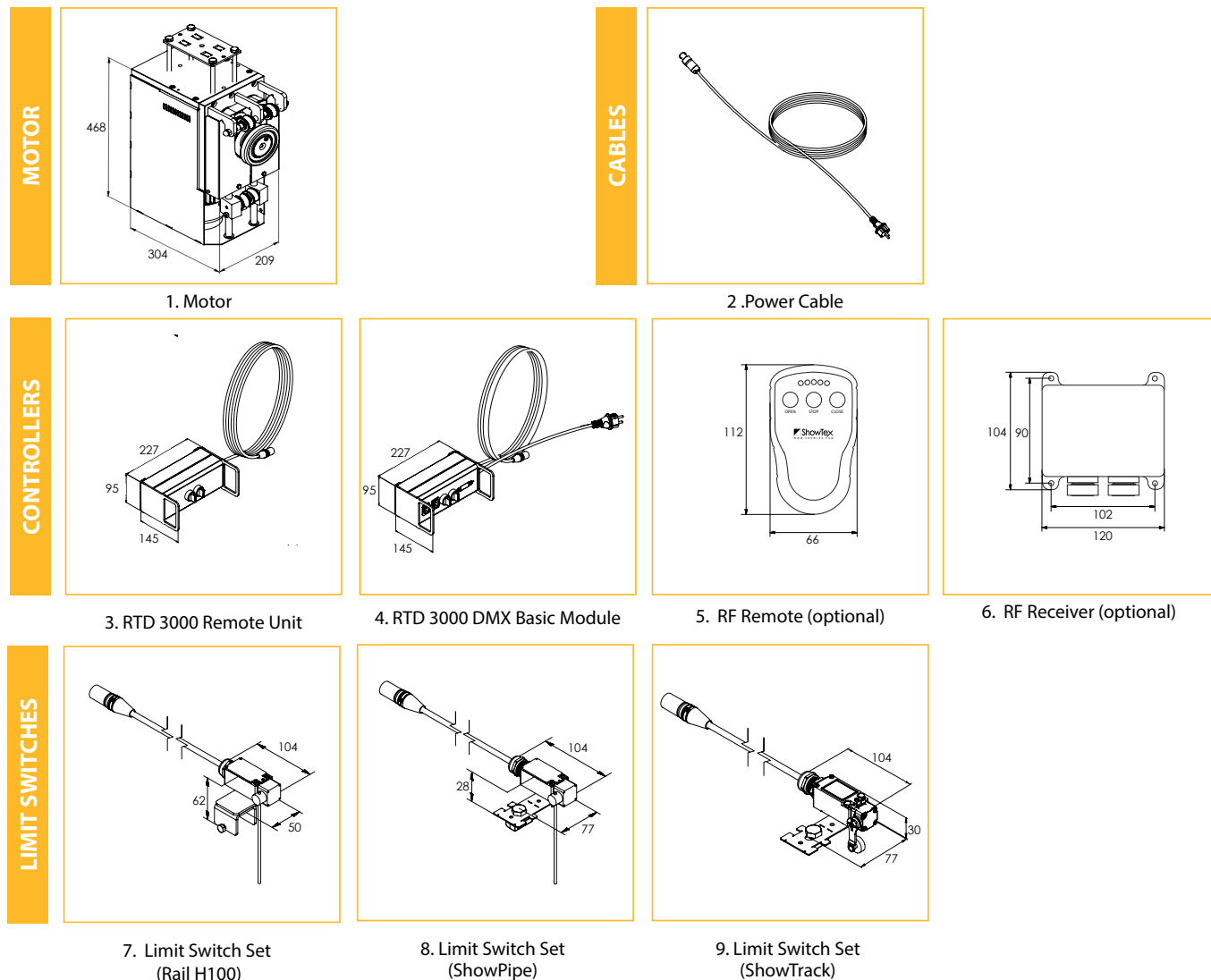

NAME	ART.NR.	WEIGHT	INFORMATION
1. RTD 3000 Motor	8050 0713 3707	37.2 kg/pc	370 W • 1 x 230 VAC • 1.89 A • 21 Nm • 138 rpm
2. Power Cable	8150 0912 0027	0.40 kg/pc	Length : 2 m
3. RTD 3000 Remote Unit	8050 0766 0020	5.40 kg/pc	With 25m cable
4. RTD 3000 DMX Basic Module	8050 0766 0100	1.92 kg/pc	Optional • With 25m cable and 2 m power cable
5. RF Remote	8050 0950 0200	0.14 kg/pc	Optional • 2.4 GHz radio • range: up to 700m (open space)
6. RF Receiver	8050 0950 0300	0.32 kg/pc	Optional • 5 channels
7. Limit Switch Set (H100)	8050 0770 0020	0.23 kg/pc	For Rail H100
8. Limit Switch Set (ShowPipe)	8050 0770 0017	0.23 kg/pc	For ShowPipe
9. Limit Switch Set (ShowTrack)	8050 0770 0015	0.23 kg/pc	For Showtrack

» ELECTRICAL WIRING & CONNECTORS

» STANDARD MANUAL CONTROL UNIT

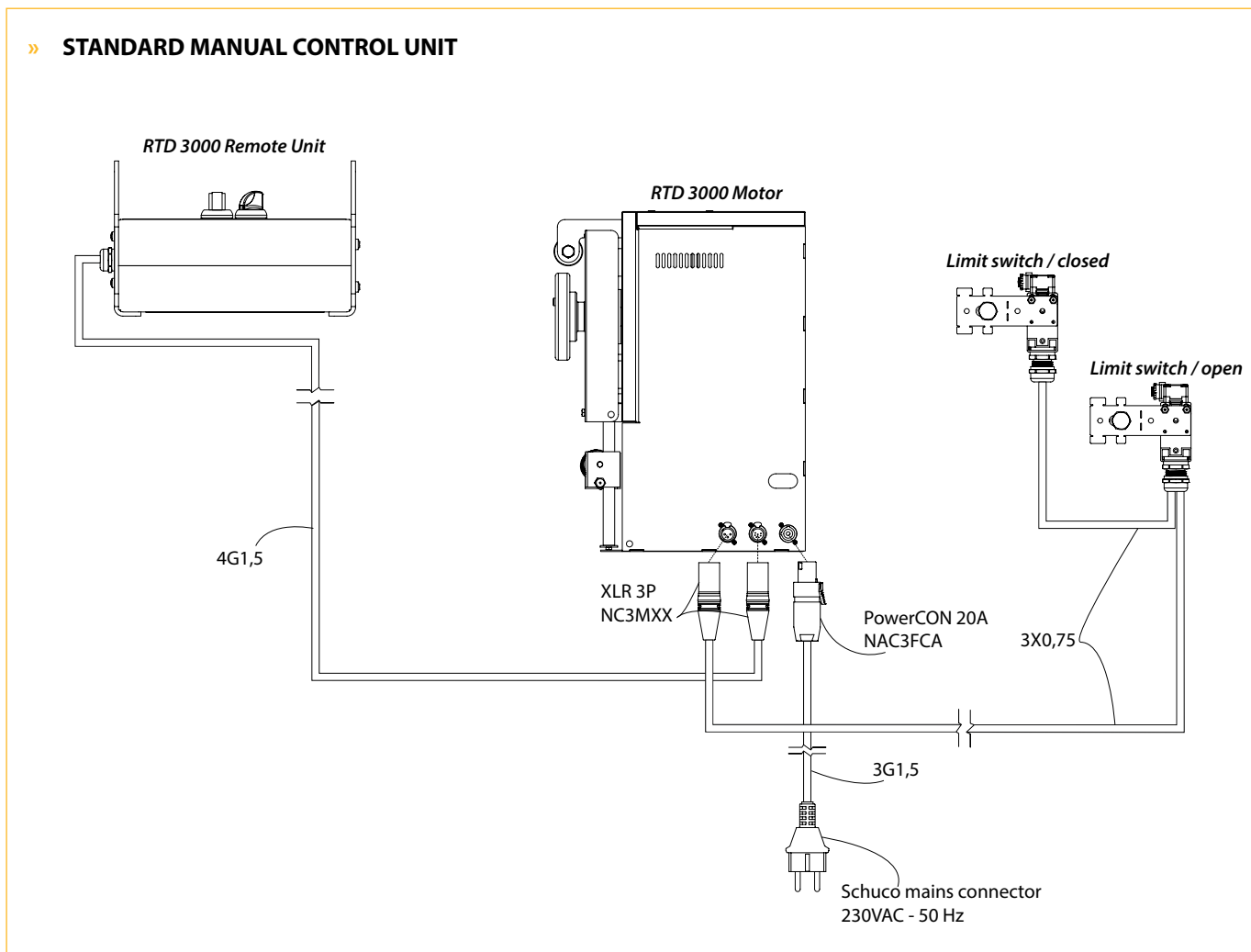

» ELECTRICAL WIRING & CONNECTORS

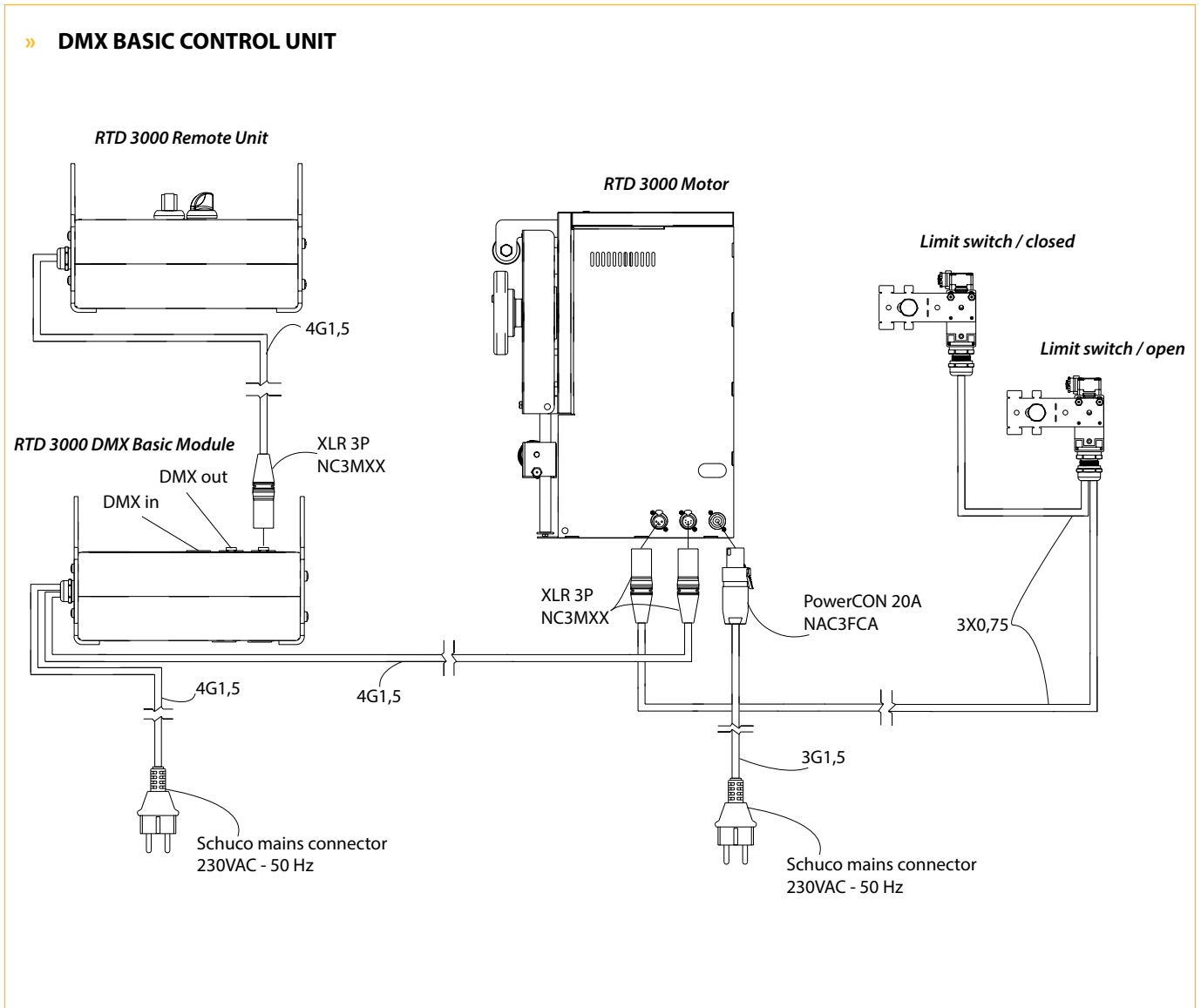

**HAVE A GREAT SHOW!**  
MORE INFO ON [WWW.SHOWTEX.COM](http://WWW.SHOWTEX.COM)