

TRAVELSCREEN

TECHNICAL DATA SHEET

February 2017

Portable projection screen with front or rear projection foil.

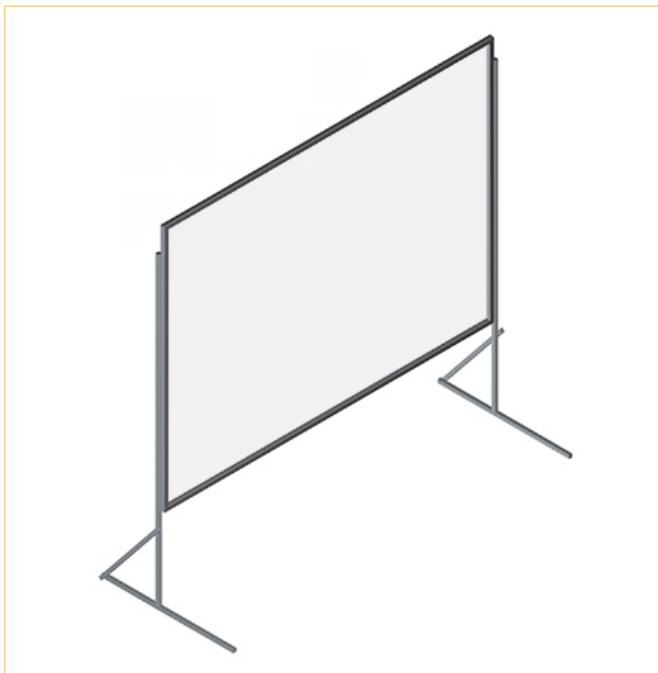

- Solid aluminum frame on two stands. Also available with an even more rigid truss-style frame for bigger dimensions.
- The ideal mobile screen for professional temporary installations. The perfect solution for mobile presentations and performances.
- Its hinge locking mechanism makes it very fast and easy to assemble. There are no parts to install and no tools needed as the frame and support utilize its own connectors and comes with thumb nuts. Its robust frame ensures it can hold up the toughest of challenges.
- The screen is fixed by multiple press studs on each frame bar, ensuring a wrinkle-free screen when installed.
- The fold-and-lock mechanism makes setup and takedown easy. It also ensures that the frame is firm and secure when in use.
- The aluminum frame is sturdy yet light in transport. All pieces fit into a very light and robust flight-case on wheels.



TRAVELSCREEN

TECHNICAL DATA SHEET

February 2017

Portable projection screen with front or rear projection foil.

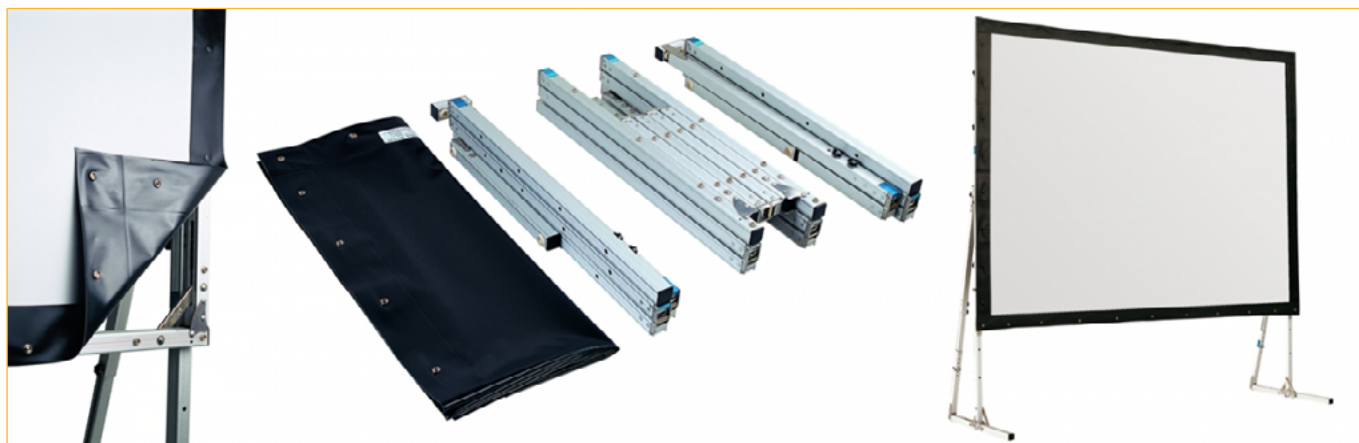

Contact your local ShowTex office for dimensions and more information.